

SHERLINE PRODUCTS

INCORPORATED 1974

Refer to *SHERLINE INSTRUCTION GUIDE*
(P/N 5326) for milling setup and operations.

Vertical Milling Column

P/N 3050 (Inch), P/N 3053 (Metric)

P/N 3480 (Inch), P/N 3485 (Metric)

with Zero Adjustable Handwheel

The Sherline lathe can be quickly and easily converted into a small milling machine with this attachment. The attachment consists of a dovetailed vertical column with a solid aluminum base that attaches to the bed of the lathe in place of the headstock. The headstock then mounts to a dovetailed saddle on the vertical column. The saddle is raised and lowered to control the depth of cut by turning a handwheel. Calibrations on the handwheel enable depth control to .001". Parts to be machined are mounted on the lathe's 2.75" x 6.00" crossslide. The headstock may be locked in position by means of a screw on the back of the saddle. (See P/N 4517 and 4033 on the exploded view.)

This is a good way to get into milling. All standard vertical milling operations can be performed with this attachment with size being the only limitation. Conversion from the lathe to the mill takes less than one minute. Just about all Sherline milling accessories may be used with this setup. (NOTE: Due to the size and weight of the P/N 3200 indexing attachment and the P/N 3700 rotary table, it is not recommended they be used with the lathe and vertical milling column combination. We recommend they be used with the Sherline vertical milling machine or XYZ base.)

NOTE: All vertical milling columns manufactured after 1995 include the modifications necessary to work with Sherline's XY Base.

Mounting Instructions

Remove the headstock from the lathe by loosening the set screw (P/N 40540) located below the name plate. Lift the headstock vertically from the bed.

Mount the vertical milling column on the lathe pivot pin (P/N 40240) on the lathe bed.

Mount the headstock on the pivot pin located on the saddle of the vertical milling column in the same manner as it is mounted on the lathe bed.

Angles can be milled by rotating the headstock with the alignment key removed. Move headstock to desired angle and tighten the set screw (P/N 40540).

Helpful Hints

1. This is a small, light duty mill, and should not be used to remove vast amounts of unnecessary stock that could be easily removed with a hacksaw. Get stock as close to size as possible before starting.
2. Loads involved for milling are higher than for lathe turning. The vibration level is also higher, therefore, more attention must be paid to gib adjustments. They should be kept snug.
3. End mills must run true and must be sharp. Holding end mills in a drill chuck is a poor method. Use milling collets or our end mill holders. For cutting aluminum, run motor top speed and take light cuts.
4. Fly cutting is an excellent way of cutting stock from flat surfaces.
5. Normal machine alignment is good for most work, but if the work is exceptionally large or has to be extremely accurate, shims may be required to improve machine alignment.
6. Learn to use a dial indicator.
7. A good mill vise is a must.
8. Often, more time will be spent making fixtures to hold work than doing the actual machining.
9. Always try to have one point to measure from. Don't machine this point off half way through the job and leave yourself without a way of measuring the next operation. PLAN AHEAD.
10. A good rule for all machining operations is: "If the tool chatters, reduce speed and increase feed."

It takes a long time to accumulate the knowledge, tools and fixtures to do the tremendous amount of different type of operations involved in milling. Don't get discouraged by starting with a job that is too complex or by using materials that are extremely difficult to machine.

Thank you,
Sherline Products Inc.

Exploded View

Vertical Milling Column

P/N 3480 (3485) w/Adjustable "Zero" Handwheel

(Metric part numbers shown in parentheses where different.)

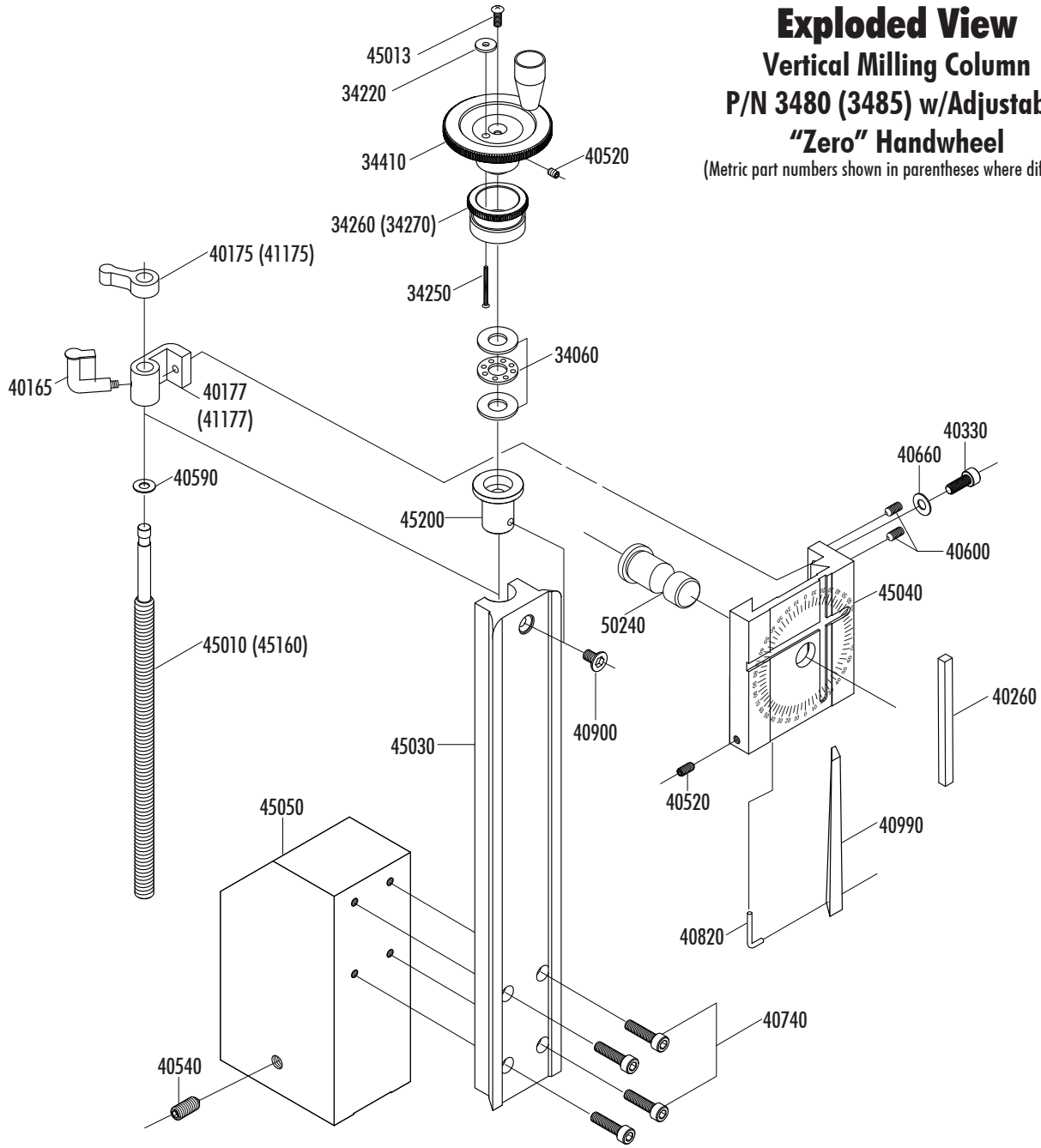

Parts List

NO. REQ.	PART NO.	DESCRIPTION	NO. REQ.	PART NO.	DESCRIPTION
1	34020	Z-Axis Handwheel Knob	2	40330	10-32 x 5/8" Skt Hd Cap Screw
1	34030	Z-Axis Handwheel Shaft	2	40520	Cup Pt Set Screws 10-32 x 3/16"
1	34060	Thrust Bearing Set	1	40540	5/16-24 x 3/4" Cone Point Set Screw
1	34070	Z-Axis Hndwhl Body (for P/N 3450 not shown) (Met. 34090)	1	40600	10-32 x 1/4" Flat Point Set Screw
1	34080	Handwheel Plug	4	40740	Skt Hd Cap Screws 10-32 x 7/8"
1	34220	Lock Nut, Adj. Handwheel (for P/N 3480)	1	40820	Gib Lock
1	34250	Lock Screw, Adj. Handwheel (for P/N 3480)	1	40900	10-32 x 3/8" Flat Head Screw
1	34260	Z-Axis Zero Adj. Hndwhl Collar (for P/N 3480) (Met. 34270)	1	40990	Saddle Gib
1	34410	Z-Axis Zero Adj. Handwheel Body (for P/N 3480)	1	45010	Column Lead Screw (Met. 45160)
1	40165	Z-Axis Oiler	1	45030	Column Bed
1	40170	CNC Saddle Nut (not shown) (Met. 41170)	1	45040	Column Saddle
1	40175	Saddle Locking Lever (Met. 41175)	1	45050	Column Base
1	40177	Saddle Nut (Met. 41177)	1	45200	Bored Column Thrust
1	40260	Head Key	1	67028	CNC Column Lead Screw (not shown) (Met. 67029)